

\* Installation template included inside

**TRITON**

# OMNICARE

## Electric Shower



### IMPORTANT SAFETY ADVICE

The shower unit **MUST BE** switched off at the isolating switch when not in use. This is a safety procedure recommended for all electrical appliances.

The shower head and hose supplied with this product are safety critical parts of your shower. Failure to use genuine Triton parts may cause injury and invalidate your guarantee.













### INSTALLATION AND OPERATING INSTRUCTIONS

Please read this book thoroughly and familiarise yourself with all instructions before commencing installation and keep it for future reference.

The shower installation **MUST** be carried out by a suitably qualified person, **in the sequence of this instruction book.**

## PLEASE READ THIS IMPORTANT SAFETY INFORMATION

Products manufactured by Triton are safe and without risk, provided they are installed, used and maintained in good working order in accordance with our instructions and recommendations.

-  **WARNING: DO NOT** operate the shower if there is a possibility of frozen water within the heater or pipes feeding the shower.
-  **DO NOT** operate the unit if the shower head or spray hose becomes damaged.
-  **DO NOT** restrict flow out of shower by placing shower head in direct contact with your body or any other surface.
-  **DO NOT** operate the shower if water ceases to flow during use or if water has entered inside the unit because of an incorrectly fitted cover.
-  **WARNING: If restarting the shower immediately after stopping, be aware that a slug of hot water will be expelled for the first few seconds.**
-  The spray head must be descaled regularly.
-  Fit only shower heads and hoses recommended by the manufacturer and never fit any additional device to restrict the water outlet flow.
-  The outlet must not be connected to any tap or fitting other than those specified by the manufacturer.
-  This appliance is intended to be permanently connected to the water mains and not connected by a hose set.
-  The water inlet of this appliance must only be connected to mains cold water only. The water inlet must never be connected through any other water heating system.
-  **WARNING:** This appliance is not to be used to provide a potable water supply.
-  Product must be installed and disconnection must be incorporated in the fixed wiring in accordance with the current wiring rules AS/NZS 3000.
-  Always disconnect the appliance from the supply before assembling, disassembling or cleaning.

Mains water pressure only.

Minimum inlet pressure 100kPa (1 bar)

Maximum inlet pressure 1000kPa (10 bar)

**This book contains all the necessary fitting and operating instructions for your electric shower.**

**Care taken during the installation will provide a long, trouble-free life from your shower.**

### **WARNING**

This appliance can be used by children aged from 3 years and above and persons with reduced physical, sensory or mental capabilities or lack of experience and knowledge if they have been given supervision or instruction concerning use of the appliance in a safe way and understand the hazards involved. Children may not play with the appliance. Cleaning and user maintenance shall not be made by children.



# IMPORTANT GUIDANCE NOTES

## PLEASE READ BEFORE PROCEEDING



### 1 GENERAL

- 1.1 Isolate the electrical and water supplies before removing the cover.
- 1.2 Read all of these instructions and retain them for later use.
- 1.3 **DO NOT** take risks with plumbing or electrical equipment.
- 1.4 Isolate electrical and water supplies before proceeding with the installation.
- 1.5 The unit must be mounted onto the finished wall surface (on top of the tiles). **DO NOT** tile up to or seal around **ANY PART** of the unit using silicone sealer after fixing to the wall. Special care must be taken **NOT TO BLOCK OR SEAL ANY PRD VENTS ON THE UNIT**.
- 1.6 Contact Customer Experience (*see back page*), if any of the following occur:
  - a) *If it is intended to operate the shower at pressures above the maximum or below the minimum stated.*
  - b) *If the unit shows a distinct change in performance.*
  - c) *If the shower is frozen.*
- 1.7 If it is intended to operate the shower in areas of hard water (above 200 ppm temporary hardness), a scale inhibitor may have to be fitted. For advice on the Scale Inhibitor, contact Customer Experience.
- 1.8 The shower head must be cleaned regularly with descalent to remove scale and debris, otherwise restrictions to the flow on the outlet of the unit will result in higher temperatures and could also cause the Pressure Relief Device (PRD) in the unit to operate.
- 1.9 This product is not suitable for mounting into steam rooms, steam cubicles or exposed to outdoor elements.

### 2 PLUMBING

- 2.1 The plumbing installation must comply with Water Regulations, Building Regulations or any particular regulations as specified by Local Water Company or Water Undertakers and should be in accordance with BS EN 806.
- 2.2 The supply pipe must be flushed to clear debris before connecting to the shower unit.

- 2.3 **Do NOT** solder fittings near the shower unit as heat can travel along pipework and damage components.
- 2.4 **DO NOT** fit any form of outlet flow control as the outlet acts as a vent for the heater can.
- 2.5 **DO NOT** use excessive force when making connections to the flexible hose or shower head, finger tight is sufficient.
- 2.6 All plumbing connections must be completed before making the electrical connections.
- 2.7 This appliance **MUST NOT** be connected to the inlet supply by a hose-set.

### 3 ELECTRICAL

- 3.1 The installation must comply with the current AS/NZS 3000 wiring rules, building regulations and any other regulations required building regulations or any particular regulations as specified by the local Electrical Supply Company.
- 3.2 This appliance **MUST** be earthed.
- 3.3 In accordance with current AS/NZS 3000 wiring rules, this appliance is to be permanently connected to the fixed wiring of the electrical mains system.
- 3.4 Make sure all electrical connections are tight to prevent overheating.
- 3.5 A 30mA residual current device (RCD) **MUST** be installed in all UK electric and pumped shower circuits. This may be part of the consumer unit or a separate unit.
- 3.6 Switch off immediately at isolating switch if water ceases to flow during use.
- 3.7 Other electrical equipment i.e. extractor fans, pumps must not be connected to the circuits within the unit.

**3.8** Switch off at isolating switch when not in use. This is a safety procedure recommended with all electrical appliances.

- 3.9 As with all electrical appliances it is recommended to have the shower and installation checked at least every two years by a competent electrician to ensure there is no deterioration due to age and usage.

# INTRODUCTION

**Please read this book thoroughly and familiarise yourself with all instructions before commencing installation**

**Please keep it for future reference.**

The shower installation **MUST** be carried out by a suitably qualified person, **in the sequence of this fitting instruction.**

## ADVICE TO USERS

**Important:** When first installed the unit will be empty. It is essential the unit should contain water before the elements are switched on. It is vital that the commissioning procedure is followed. Failure to carry out this operation will result in damage to the unit and will invalidate the guarantee.

The following points will help you understand how the shower operates:

### a) Temperature/flow rate

The temperature control can be adjusted to provide shower temperatures between 30°C and 43°C.

Alternatively, the maximum temperature can be restricted to 41°C or BEAB care by adjusting the temperature stop mechanism inside the unit.

**Important:** To comply with BEAB care mark requirements the unit must not be able to run hotter than 41°C (this is used in healthcare or special needs environments).

The **Omnicare thermostatic** unit is factory set at 43°C (nominal), see page 20 on how to adjust the **MAXIMUM** temperature to 41°C

At a selected showering temperature the unit will provide the optimum flow rate possible.

Note the flow rate for any showering temperature will be greater in the summer than in the winter because of the variance in the ambient mains water supply temperature.

### b) Temperature stabilisation

The shower will maintain temperature in accordance with the BEAB care mark.

**DO NOT** place items such as soap or shampoo bottles on top of the unit. Liquid could seep through the joint between the cover and backplate, and possibly damage the sealing rubber.

**IT IS ADVISED THAT WHERE THE PROPERTY IS LEFT UNATTENDED FOR AN EXTENDED PERIOD OF TIME, THAT THE WATER AND ELECTRICITY SUPPLIES TO THE SHOWER ARE ISOLATED.**

PRODUCT FICHE		
Model	8.5kW	9.5kW
Load Profile	XS	XS
Energy Efficiency Class	A	A
Energy Efficiency (%)	39	39
Annual Electricity Consumption (kWh)	474	473
Sound Power Level (db)	15	15

## OMNICARE MODELS

Product Variant		Safe-set™ Temperature	Looped Lever Handle	Analogue Drain Pump Connection	Code
Omnicare	8.5kW	✓	✘	✓	TEOMN81
	9.5KW	✓	✘	✓	TEOMN91
	8.5kW	✓	✘	✓	TEOMN281
	9.5kW	✓	✘	✓	TEOMN291
Omnicare Design	8.5kW	✓	✓	✓	TEOMND81
	8.5kW	✓	✓	✓	TEOMD81U
	9.5kW	✓	✓	✓	TEOMND91
	9.5KW	✓	✓	✓	TEOMD91U
Omnicare Design Export	8.5kW	✓	✓	✓	*XEOMND81
	9.5kW	✓	✓	✓	*XOEMND91

\*For spare parts and service enquiries in Ireland, please see page 33 for contact details.

To check the product suitability for commercial and multiple installations, please contact Triton's specification advisory service before installation. Please see back of book for contact information.

### WEEE Directive – Policy Statement

As a producer and a supplier of electric showers, Triton Showers is committed to the protection of the environment via our own environmental policy and the compliance with the **WEEE directive**.

Triton Showers is fully registered with the Environment Agency under the following schemes:

Repic: Producers take-back scheme (PTS), registration number WEE/EJ3466QV

Valpak: Distributor take-back scheme (DTS), registration number DTS-700160



All our electric products are labelled accordingly with the crossed out wheeled bin symbol. This indicates, for disposal purposes at end of life, that these products must be taken to a recognised collection points, such as local authority sites/local recycling centres; this will be free of any charges. **Do not return to Triton Showers.**

# CONTENTS

	Page
<b>Important Safety Information</b> .....	2
<b>Introduction</b>	
Advice to Users .....	4
Product Fiche .....	4
Omnicare Models .....	5
WEEE Policy Statement.....	5
<b>Specifications</b> .....	7
<b>Main Components</b> .....	8
<b>Dimensions, Water and Cable Entry Points</b> .....	9
Electrical .....	9
Plumbing .....	9
<b>Installation Requirements</b>	
Plumbing .....	10
Siting of the shower .....	11
Electrical .....	12
<b>Installation</b>	
Plumbing .....	14
Fixing to the Wall .....	15
Electrical .....	16
Drain Pump Connectivity .....	17
Shower Settings Setup .....	19
Commissioning .....	20
Adjusting the Maximum Temperature Stop .....	21
BEAB Care .....	22
Fitting the Cover .....	23
<b>Operating Instructions</b> .....	24
<b>Maintenance</b>	
Cleaning the Filter .....	27
BEAB Care .....	28
<b>Fault finding/Troubleshooting</b> .....	31
Alternative Format User Instructions.....	32
<b>Spares</b> .....	33
<b>UK Service policy / Guarantee, etc.</b> .....	Rear

# SPECIFICATION

## ELECTRICAL

Nominal Power Rating at 230V	7.8kW	8.7kW
Nominal Power Rating at 240V	8.5kW	9.5kW
Supply Fuse/Miniature Circuit Breaker (MCB)	8.5kW - 40Amps	
	9.5kW - 45Amps	
Residual Current Device (RCD)	30mA	
Isolation Switch	45Amp Double Pole Isolating Switch, with 3mm Minimum Contact Gap	
Supply Cable	Maximum is 16mm, refer to Electrical Requirements section	

## PLUMBING (see page 10 for plumbing requirements)

Supply Source	Mains pressure cold water only	
Minimum Dynamic Pressure and flow to the inlet of the shower	100kPa (1.0 bar) at 8 litres per minute <i>50kPa (0.5 bar) at 8 litres per minute under adnormal conditions</i>	
Maximum Static Pressure	1000 kPa (10 bar)	
Maximum inlet temperature	28°C (20°C BEAB Care)	
Minimum inlet temperature	2°C (5°C BEAB Care)	
Inlet connection	15mm diameter	
Outlet connection	½" BSP male thread	

## MATERIALS

ABS	Backplate, cover, controls, shower head	
Minerally insulated corrosion resistant metal sheathing	Elements	

## ACCREDITATIONS

**R N I B**

Tried and Tested

**BEAB CARE**

Intertek

**BEAB Approved**

Intertek



IP25

# MAIN COMPONENTS

Inside the unit

Inside the Cover

**Note:** Wires have not been shown for reasons of clarity.

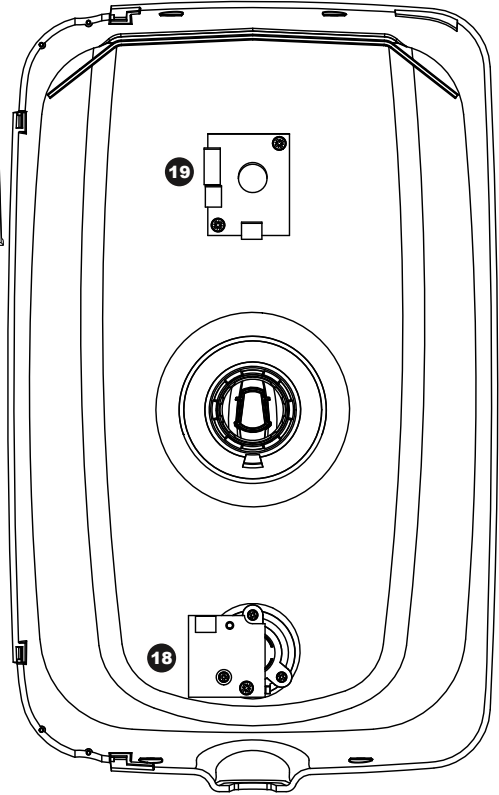
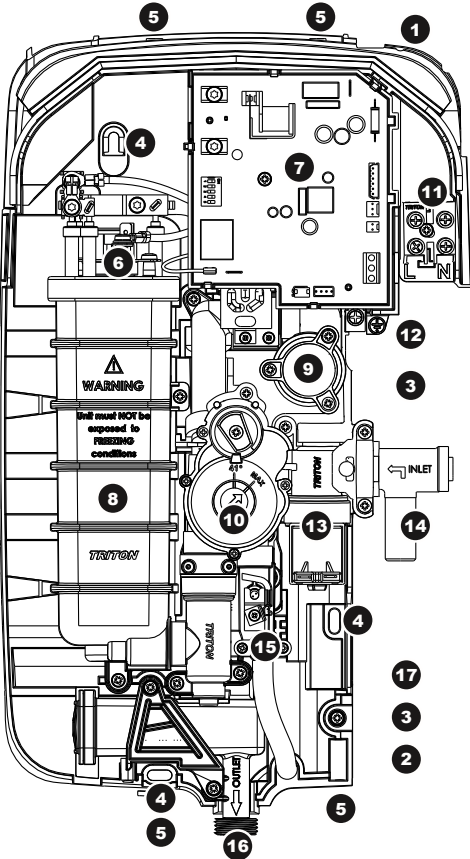

- |                                |   |                                  |
|--------------------------------|---|----------------------------------|
| 1. Top cable and pipe entry    | 8. Can and element assembly                           | 14. Water inlet                  |
| 2. Bottom cable and pipe entry | 9. Pressure switch                                    | 15. Pressure relief device (PRD) |
| 3. Rear cable and pipe entry   | 10. Thermostatic valve & maximum temperature selector | 16. Shower outlet                |
| 4. Wall screw fixings          | 11. Terminal block (L & N)                            | 17. Splashguard (not shown)      |
| 5. Cover screw fixings         | 12. Earth connection                                  | 18. Start/Stop PCB               |
| 6. Thermal safety cut-out      | 13. Solenoid valve                                    | 19. Control PCB                  |
| 7. Power PCB                   |   |                                  |

# DIMENSIONS & ENTRY POINTS

Omicare

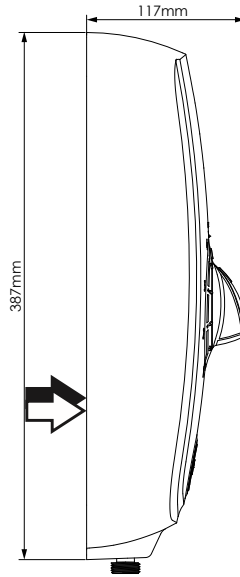
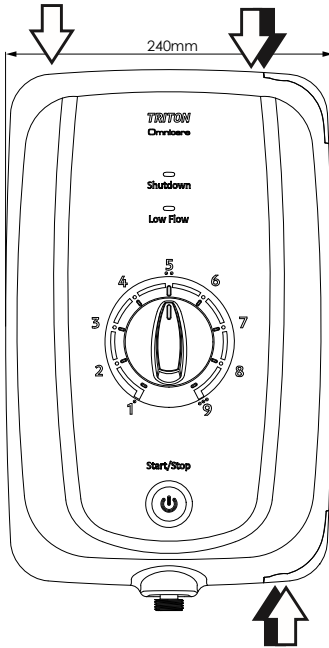
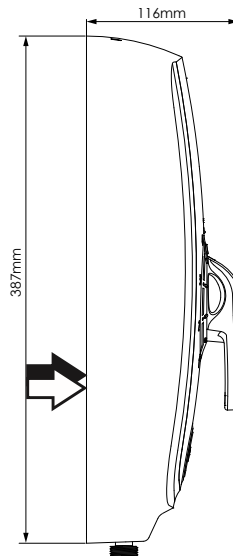
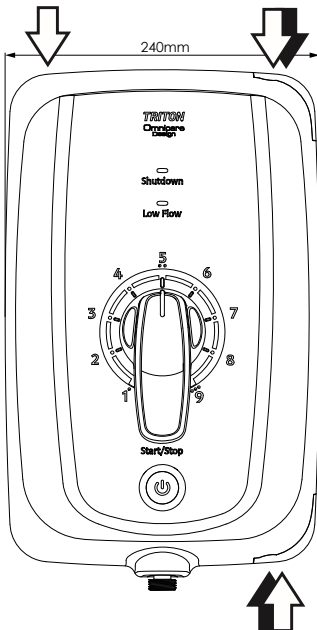

**Diagram Key:**

 **Water**  
Entry Points

 **Electrical Cable**  
Entry Points

Omicare Design



# INSTALLATION REQUIREMENTS

## PLUMBING REQUIREMENTS

Refer to **IMPORTANT SAFETY INFORMATION** and **SPECIFICATION** sections before undertaking installation.

**Note: if the recommended dynamic pressure and flow is not available, there will be a noticeable reduction in flow from the shower head.**

Please avoid installations subject to regular and rapid changes in water supply pressure.

If it is intended to operate the shower at pressures above the maximum or below the minimum stated, contact Customer Experience for advice.

1. The installation must be in accordance with Water Regulations/Bylaws.
2. **DO NOT** use jointing compounds on any pipe fittings for the installation.
3. **DO NOT** solder fittings near the shower unit as heat can travel along pipework and damage components.
4. A compression or demountable push-fit fitting can be used to connect to the shower inlet.
5. **Note:** Do not use a push-fit fitting that does not allow the inlet to be disconnected for servicing i.e. a non-demountable push-fit fitting.
6. **Important:** An additional stop valve (complying with Water Regulations) **Must** be fitted in the mains water supply to the shower as an independent means of isolating the water in order to carry out maintenance or servicing. If this isolator is fitted in a loft space, the loft must have a fixed access ladder and be boarded, with appropriate lighting from the access point to the isolator. **To comply with BEAB care mark in service testing procedure, the isolating valve should be located close to the shower unit.**
7. **Important:** Before completing the connection of the water supply to the inlet of the shower, flush out the pipework to remove all swarf and system debris. This can be achieved by connecting a hose to the pipework and turning on the mains water supply long enough to clear the debris to waste.
8. **Important:** The unit must be mounted on a flat surface which covers the full width and length of the backplate. It is important that the wall surface is flat otherwise difficulty may be encountered when fitting the cover and subsequent operation of the unit may be impaired.
9. **Position of the shower:** Refer to **Fig.1** for correct positioning of shower. Position the unit where it will not be in direct contact with water from the shower head. Always mount the shower unit vertically and allow enough room between the ceiling and the shower to access the cover top screws.

**IMPORTANT Water Regulations:** It is required that the shower head be 'constrained by a fixed or sliding attachment so that it can only discharge water at a point not less than 25mm above the spill-over level of the relevant bath, shower tray or other fixed appliance'.

If the riser kit is supplied with a bespoke 'hose retainer', it will in most cases meet this requirement. If the shower head can still be placed within a bath, basin or shower tray within the 25mm limit, then a double check valve, or similar, **MUST be fitted in the supply pipework to prevent back-flow.**

# INSTALLATION REQUIREMENTS

**Fig.1** Diagrammatic view (not to scale)  
For illustration purposes only. Kits may vary.

## WARNING

The shower **MUST NOT** be positioned where it will be subjected to freezing conditions.

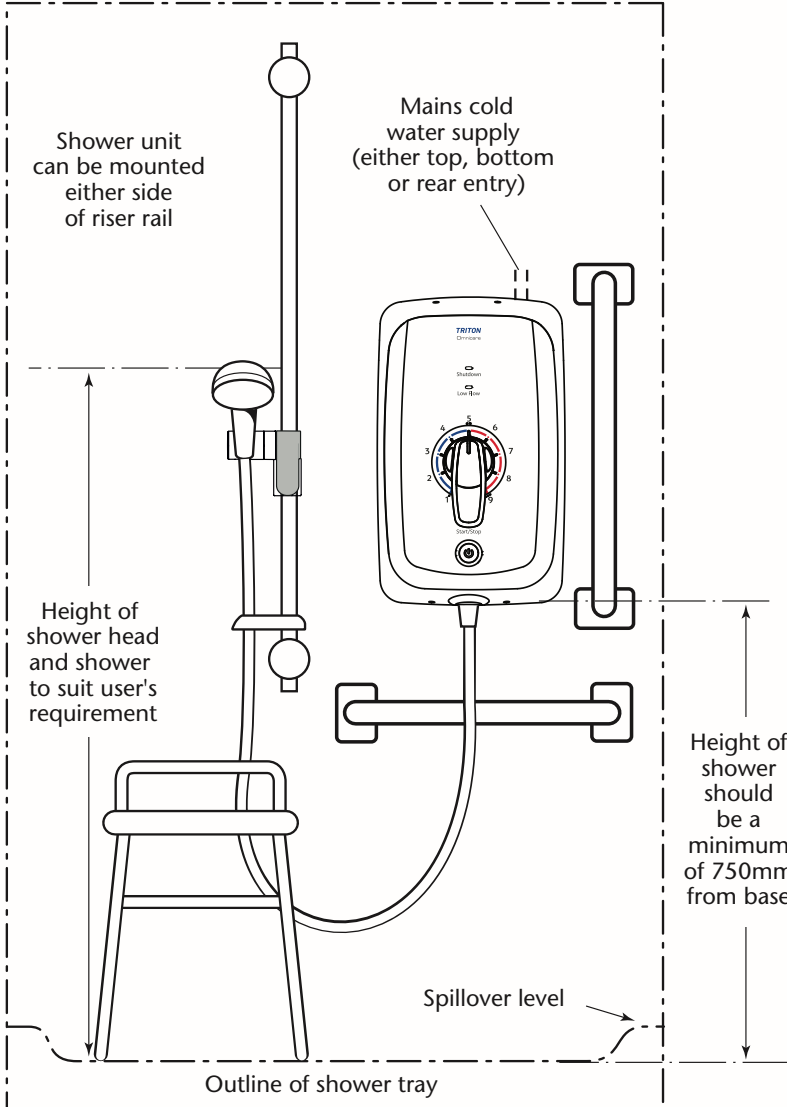

# INSTALLATION REQUIREMENTS

## ELECTRICAL REQUIREMENTS

Refer to **IMPORTANT SAFETY INFORMATION** and **SPECIFICATION** sections before undertaking installation.

The installation, supply cable and circuit protection must conform with BS 7671 (IEE wiring regulations) and be sufficient for the amperage required.



**WARNING:** This Appliance must be earthed by connecting the supply cable earth conductor to the terminal block within the appliance.

### The following notes are for guidance only:

1. The shower must only be connected to a 230-240V ac supply. Any drops in voltage due to localised heavy demand may reduce the shower's performance
2. The electrical rating of the shower is shown on the rating label (**Fig.3**) within the unit.
3. Before making any sort of electrical connection within the installation make sure that no terminal is live. If in any doubt, switch off the whole installation at the mains supply and remove the correct fuse.
4. The shower must be connected to its own independent electrical circuit. **IT MUST NOT** be connected to a ring main, spur socket outlet, lighting circuit or cooker circuit.
5. The electrical supply must be adequate for the loading of the unit and existing circuits.
6. Check your consumer unit (main fuse box) has a main switch rating of 80Amps or above and that it has a spare fuse way which will take the fuse or Miniature Circuit Breaker (MCB) necessary for the shower rating.
7. If your consumer unit has a rating below 80A or if there is no spare fuse way, then the installation will not be straightforward and may require a new consumer unit serving the house or just the shower. Contact a professional electrician/local electricity company for advisement.
8. For close circuit protection **DO NOT** use a rewireable fuse. Instead use a suitably rated Miniature Circuit Breaker (MCB) or cartridge fuse. Triton recommend the following circuit protection:  
**8.7KW - 40Amp    9.8kW - 45Amp**
9. A 30mA residual current device (RCD) **MUST** be installed in all UK electric and pumped shower circuits. This may be part of the consumer unit or a separate unit.

**Fig.2**

### Twin and earth PVC insulated cable Current carrying capacity

Installed in an insulated wall	In conduit trunking	Clipped direct or buried in a non-insulated wall
6mm <sup>2</sup> 32A	6mm <sup>2</sup> 38A	6mm <sup>2</sup> 46A
10mm <sup>2</sup> 43A	10mm <sup>2</sup> 52A	10mm <sup>2</sup> 63A
16mm <sup>2</sup> 57A	16mm <sup>2</sup> 69A	16mm <sup>2</sup> 85A

**Note:** Cable selection is dependent on derating factors

**Fig.3**

Triton Showers  
Triton Road, Nuneaton  
Warwickshire, CV11 4NR.

---

MODEL OMNICARE  
230 - 240V ~ IP25

X.X - X.XkW

MAX PRESSURE 1000kPa (10bar)

MIN PRESSURE 100kPa (1bar)

RATED PRESSURE 0kPa (0bar)

MODEL No. XXXXXXXX  
SERIAL No. XXXXXXXX

*Safety Assured*  
  
**XX/XX**

# INSTALLATION REQUIREMENTS

10. A 45 amp double pole isolating switch with a minimum contact gap of 3mm in both poles must be incorporated in the circuit (**Fig.4**). It must have a mechanical indicator showing when the switch is in the OFF position, and the wiring must be connected to the switch without the use of a plug or socket outlet.
11. The switch must be accessible and clearly identifiable, but out of reach of a person using a fixed bath or shower, except for the cord of a cord operated switch, and should be placed so that it is not possible to touch the switch body while standing in a bath or shower cubicle. It should be readily accessible to switch off after using the shower.
12. Where shower cubicles are located in any rooms other than bathrooms, all socket outlets in those rooms must be protected by a 30mA RCD.
13. The current carrying capacity of the cable must be at least that of the shower circuit protection (**Fig.2**). To obtain full advantage of the power provided by the shower, use the shortest cable route possible from the consumer unit to the shower.
14. The shower circuit should be separated from other circuits by at least twice the diameter of the cable or conduit. The current rating will be reduced if the cabling is bunched with others, surrounded by thermal loft or wall insulation or placed in areas where the ambient temperature is above 30°C. Under these conditions, derating factors apply and it is necessary to select a larger cable size. In the majority of installations (**Fig.2**), the cable will unavoidably be placed in one or more of the above conditions. This being so, it is strongly recommended to use a minimum of 10mm cabling throughout the shower installation. In any event, it is essential that individual site conditions are assessed by a competent electrician in order to determine the correct cable size and permissible circuit length.

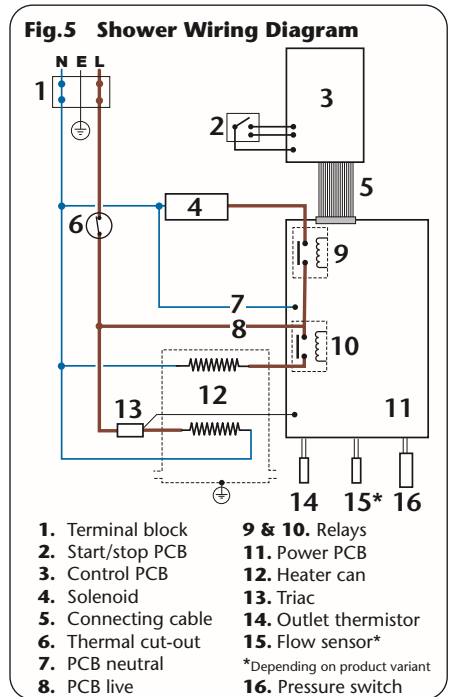
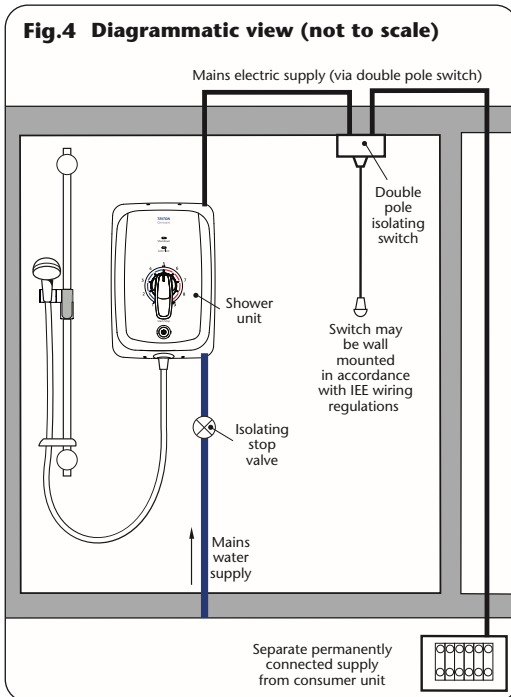

# INSTALLATION

## POSITIONING THE SHOWER

For ease of servicing, the unit must always be mounted on the surface of tiled walls.

Never tile up to the unit.

Position the unit where it will not be in direct contact with water from the shower head.

Mount the shower unit vertically.

Allow enough room between the ceiling and the shower to access the top cover screws.

Using the supplied template in the centre of this booklet, mark out the entry points and routing of the water and electric supplies into the shower.



Find our step-by-step installation video for this product on our YouTube channel. Go to [youtube.com/TritonShowers](https://www.youtube.com/TritonShowers) and search for 'how to guides'.

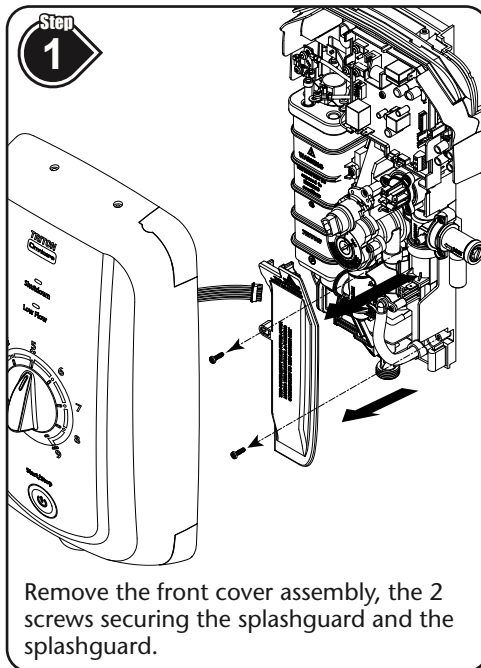

Remove the front cover assembly, the 2 screws securing the splashguard and the splashguard.

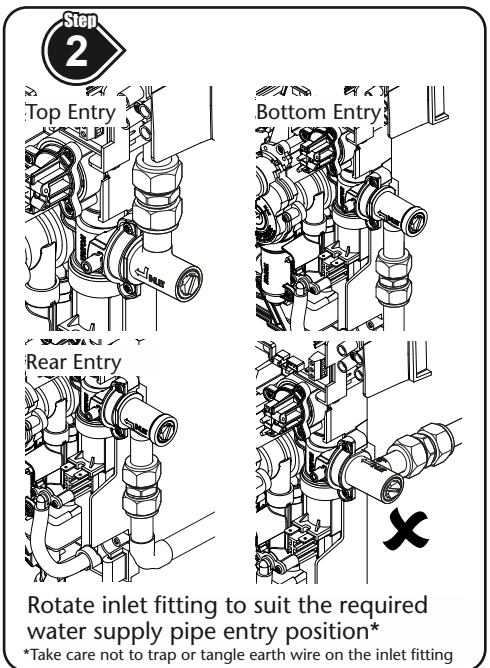

Rotate inlet fitting to suit the required water supply pipe entry position\*

\*Take care not to trap or tangle earth wire on the inlet fitting



- Complete all the plumbing pipework.
- Ensure that any soldering of pipework is done away from the shower as heat can travel along pipework and damage components.

**IMPORTANT:** Before connecting the shower to the plumbing pipework flush out the pipework for approximately 60 seconds to remove any swarf or debris.



# INSTALLATION

Step  
6

- Route the electrical supply cable into the shower unit.

**Note:** The supply cable must be secured either by routing through conduit, trunking or by embedding in the wall, in accordance with IEE regulations.

- Insert the conductors into the appropriate position on the terminal block.

**Note:** The earth conductor must be sleeved. The outer sheath of any conductor must be stripped back to a minimum.

- Fully tighten the terminal block screws and make sure that no cable insulation is trapped under the screws.

**IMPORTANT:** Loose connections can result in cable overheating.

**DO NOT** switch on the electricity supply.

Earth cable (Green/Yellow) to   
Neutral cable (Blue or Black) to **N**  
Live cable (Brown or Red) to **L**

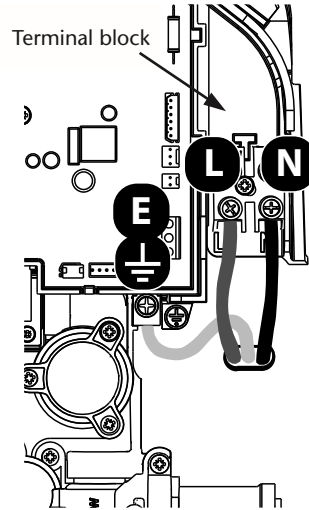

Step  
7

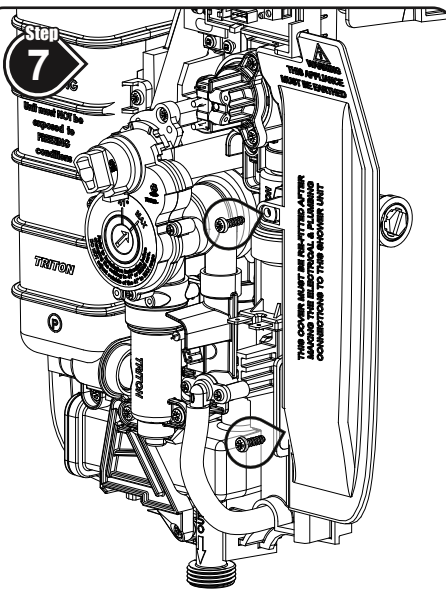

Refit the splashguard and secure with the 2 fixing screws.

Step  
8-1

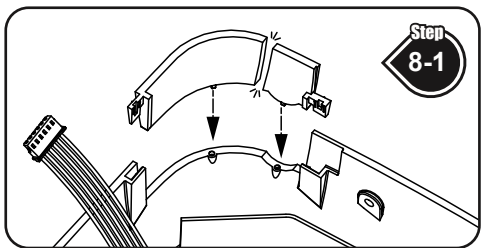

The trimplates have a cut guide design. Position the cover to the shower, make removable marks for the width and depths for the trunking and pipework then make the cut and install the trim.

Step  
8-2

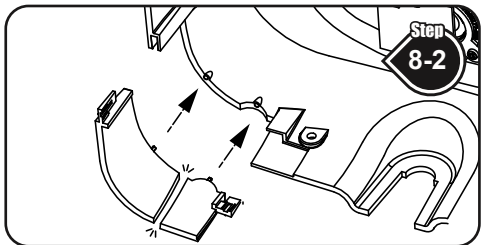

# INSTALLATION

Step

9

## DRAIN PUMP CONNECTIVITY

(If no drain pump is being connected to the shower then this step can be ignored)

This Omnicare product has been designed to operate with analogue pumps only.

### Configuration 1 for Analogue Drain Pumps

When the shower is turned on, a signal is sent to the drain pump electronics telling the pump to start. When the shower is turned off, a signal is sent again to the drain pump electronics telling the pump to stop; generally after a preset time delay. This type of pump makes no allowance for the flow rate of the water from the shower, the 'gulp' or speed of the pump is fixed.

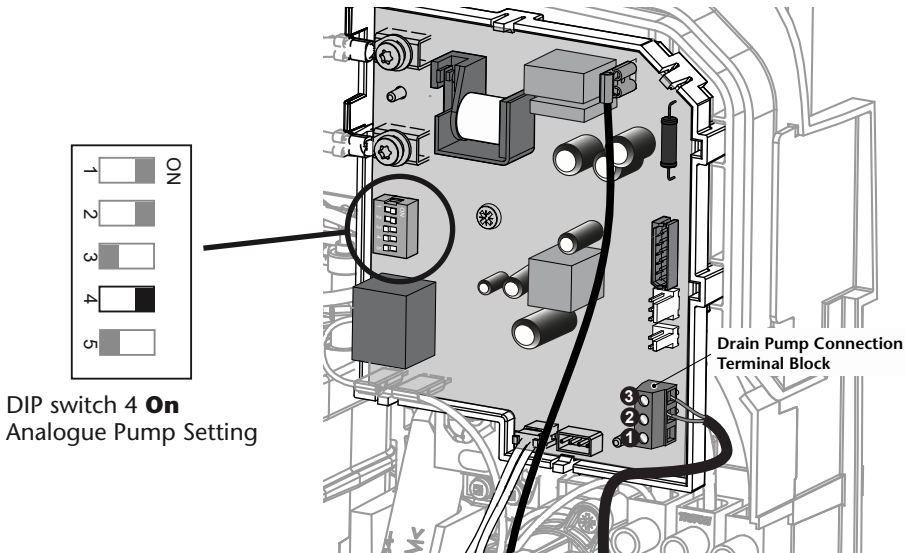

The pump manufacturer provides a two core cable for connection to the shower unit.

Connect the drain pump Control Wire as below:

- 1 - Not Used (connections numbered from bottom)
- 2 - Any
- 3 - Any

**Note: Please reference the relevant pump manufacturer's installation instructions for pump connection and relevant IEE regulations.**

# INSTALLATION

## SHOWER SETTINGS SETUP

Step  
**10**

The Omnicare shower has some functionality settings that can be customised to individual user's preference. A DIP switch mounted on the Power PCB allows these settings to be adjusted.

### Factory Settings

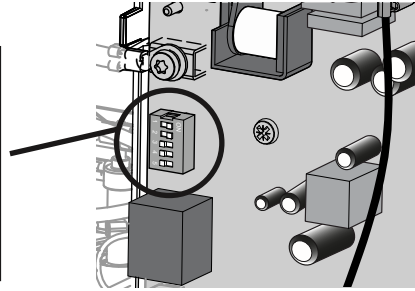

### Audible Feedback

This function provides an audible notification to specific shower operations and warnings.



DIP switch 1 **On** = Audible Feedback **On (Factory Settings)**



DIP switch 1 **Off** = Audible Feedback **Off**

### Timed Shutdown

This function provides the adjustment in the length of time the shower runs before it automatically enters phased shutdown.

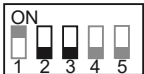

DIP switch 2 **Off**/DIP switch 3 **Off** = Timed shutdown of **5mins**

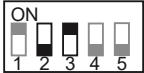

DIP switch 2 **Off**/DIP switch 3 **On** = Timed shutdown of **10mins**

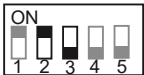

DIP switch 2 **On**/DIP switch 3 **Off** = Timed shutdown of **20mins (Factory Settings)**



DIP switch 2 **On**/DIP switch 3 **On** = Timed shutdown of **30mins**

# INSTALLATION

## COMMISSIONING THE SHOWER

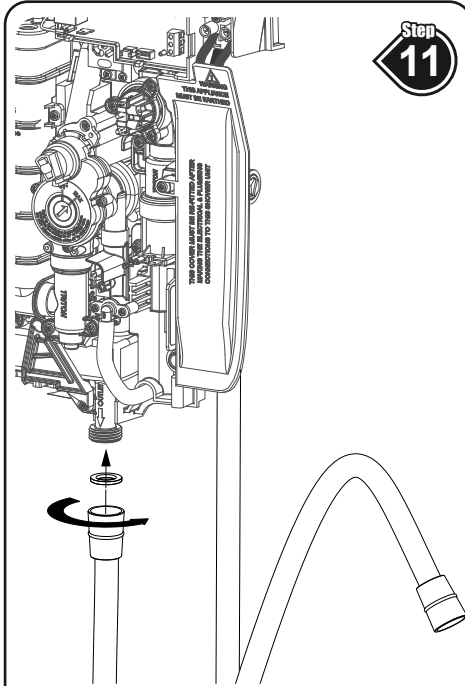

Step  
11

Attach the appropriate end of the shower hose to the shower outlet using the supplied hose washer seal - **DO NOT** overtighten. Position the other end of the shower hose to the bath or tray waste. **DO NOT** fit the shower head.

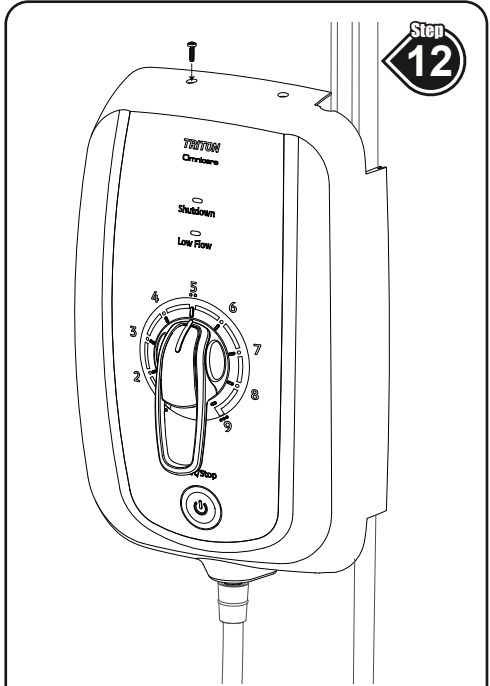

Step  
12

Temporarily fit the cover to the shower. **DO NOT** connect the wire from the cover to shower unit PCB, minor adjustment of the temperature dial may be necessary to align with the valve. Secure the cover in position with one of the retaining screws.

Step  
13

- Turn on the water supply to the shower at the isolating stop valve.
- Switch on the electricity supply to the shower at the isolating switch.
- Water will start to flow from the shower hose.
- Allow water to flow for approximately 60 seconds, this will allow the air to bleed from the installation.
- Isolate the electricity to the shower at the isolating switch. The water will cease to flow.
- Remove the cover retaining screw and lift off the cover.

**Note: The shower will only run water for approximately 90 seconds. If a longer time period is required, isolate the electricity supply, wait a few seconds and reapply the electricity supply and water will flow for 90 seconds again.**

# INSTALLATION

Step  
**14**

## ADJUSTING THE MAXIMUM TEMPERATURE TO 41°C

(If not adjusting the maximum temperature then this step can be ignored)

The shower unit is supplied factory set to give a nominal maximum temperature of 43°C, however, the temperature selector mechanism can be adjusted to restrict the maximum temperature to 41°C. Follow the instruction below to adjust the setting. Ensure that the electricity supply has been isolated before starting.

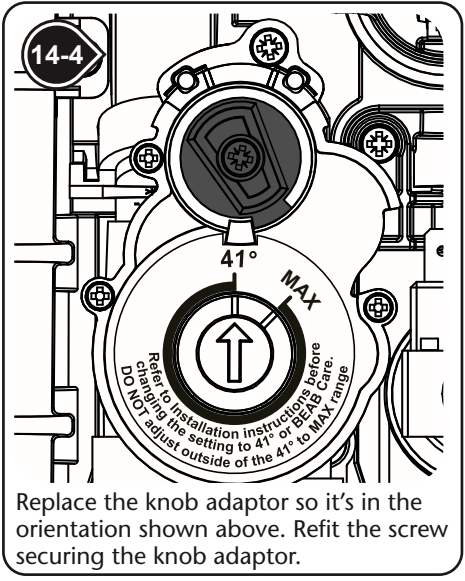
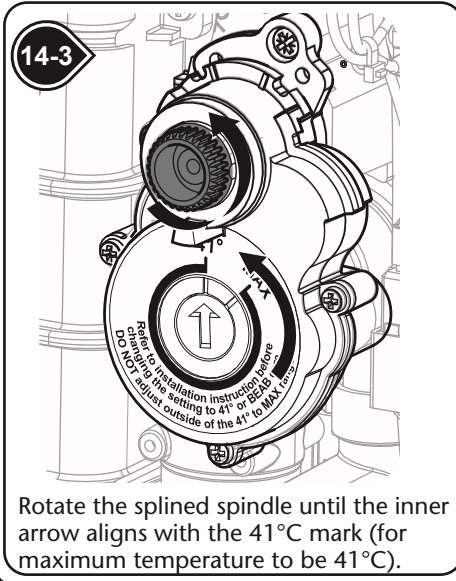
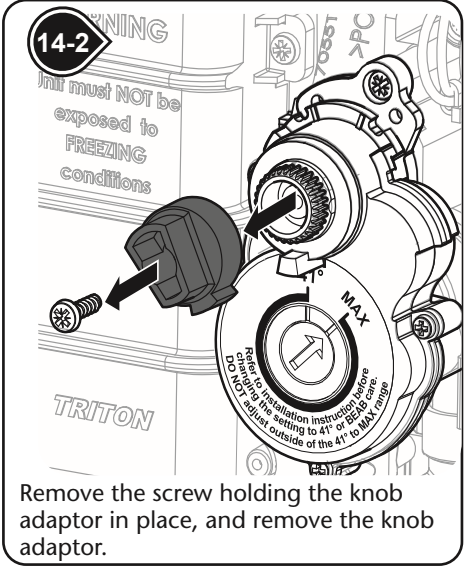
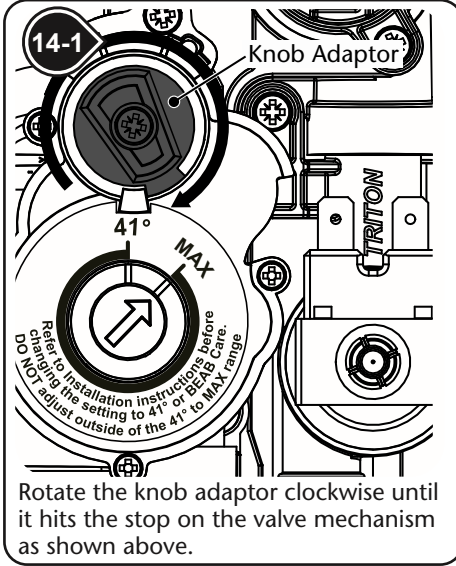

# INSTALLATION

## BEAB CARE\* MAXIMUM TEMPERATURE

(If not adjusting to BEAB Care then this step can be ignored)



**IMPORTANT:** This process should only be performed by a qualified engineer  
\*BEAB care mark specification states a **MAXIMUM** of 41°C outlet temperature.  
If the shower is adjusted above the maximum 41°C the product falls outside the BEAB care mark specification.

Ensure that the electricity supply has been isolated before starting.

- Rotate the knob adaptor clockwise until it hits the stop on the valve mechanism, see (14-1)
- Remove the screw holding the knob adaptor in place and remove the knob adaptor, see (14-2)
- Rotate the splined spindle until the inner arrow aligns with the 41°C mark, see (14-3)
- Connect the 6-way cable from the cover to the socket on the power PCB cable.

**Note:** The cable connector can be fitted to the socket one way only.

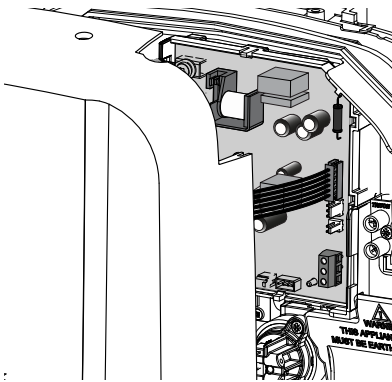

- Temporarily fit the cover to the shower, minor adjustment of the temperature dial may be necessary to align with the valve. Secure the cover in position with one of the retaining screws.
- Restore the electricity supply to the shower.
- Check the water temperature is within the range of 5 -20°C.
- Check the terminal voltage at the appliance is within 230V +/-10%.
- Start the shower by pressing the start/stop button.
- Measure the outlet water temperature at the shower head.

**Run the shower for a minimum of 30 seconds to allow the water temperature from the shower head to stabilise.**

- Adjust the splined spindle until 41°C is achieved from the shower - rotate clockwise to increase the temperature or anti-clockwise to decrease the temperature.
- Isolate the electricity.
- Remove the cover and unplug the 6-way cable from cover to the power PCB.
- Replace the knob adaptor so it is in the orientation shown in (14-4) and refit the screw securing the knob adaptor.

**After the cover has been permanently fitted, perform the maintenance checks detailed on page 28.**

# INSTALLATION

Step  
**16**

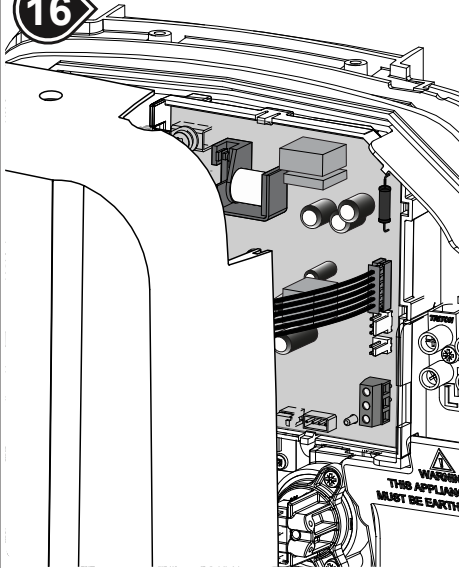

Connect the 6-way cable from the cover to the socket on the power PCB cable.

**Note:** The cable connector can only be fitted to the socket one way.

Step  
**17**

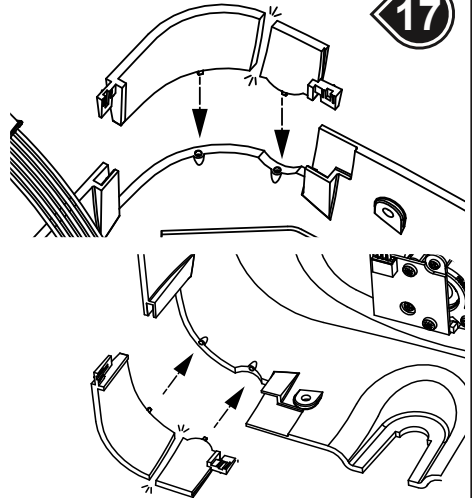

Depending on pipe and cable entry positions, click either or both the top and bottom trims into position.

Turn the electric supply back on at the isolating switch. The **power** indicator will light. No water will flow now until the **start/stop** button is pressed.

Step  
**18**

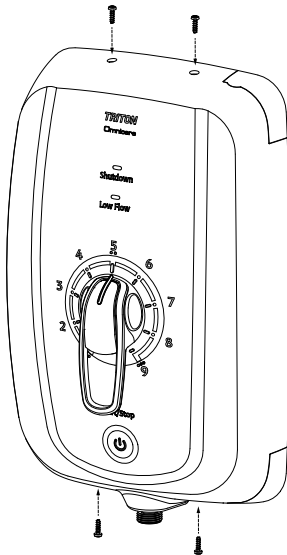

Guide the cover into position so that the temperature selector locates correctly onto the valve, minor adjustment of the temperature dial may be necessary to align with the valve.

Apply slight pressure to the cover and secure in position with the 4 retaining screws.

## OPERATING INSTRUCTIONS

1



**Switch ON the electricity supply at the isolating switch.**

Check that the power on indicator in the centre of the start/stop button is illuminated with a green light.

2



**Start the shower by pressing the Start/Stop button.**

After a few seconds the water will start to flow from the shower head.

3



**Adjust the Temperature Control to your preference.**

Rotating the control clockwise will make the water hotter, rotating the control anti-clockwise will make the water cooler.

4

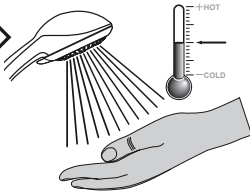

**Check the temperature of the water before showering.**

5



**Stop the shower by pressing the Start/Stop button.**

Water will continue to flow for a few seconds, purging any remaining hot water from the shower.

6



**Switch OFF the electricity supply at the isolating switch.**

DO NOT isolate the electricity supply until water has stopped flowing.

## OPERATING INSTRUCTIONS

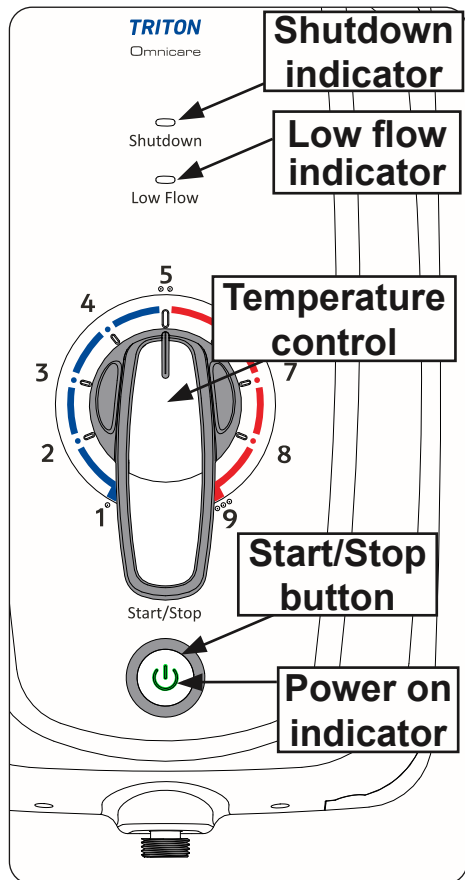

**Shutdown indicator**

TRITON  
Omnicare

Shutdown

**Low flow indicator**

Low Flow

**Temperature control**

**Start/Stop button**

**Power on indicator**

### Power On Indicator

The power on indicator will illuminate with a green light when there is an electricity supply to the shower.

### Low Flow Indicator

If a low flow condition occurs during showering, the unit will turn off the water flow immediately and illuminate the low flow indicator with a red light. If the audible function is selected, a rapid audible beep will also sound for 5 seconds. It will be necessary to wait until water in the unit has reduced to a comfortable temperature, at which point the red illuminated indicator will go off. Pressing the start/stop button will then restart the unit.

### Shutdown Indicator

This will illuminate with a yellow light if either a 'Timed Shutdown' has been initiated by the shower unit, or the Start/Stop button has been pressed to stop the shower. When a 'Timed Shutdown' has been initiated by the shower unit, the indicator illuminates 1 minute before the end of the timed shutdown period, the indicator will then flash for the remaining 10 seconds of the timed shutdown period before automatically switching off the shower, an audible beep will also commence if it has been set to do so.

## OPERATING INSTRUCTIONS

### Phased Shutdown

In use, every time the Start/Stop button is pressed, power is switched off to the elements. Water will continue to flow for a few seconds, purging any remaining hot water. This makes sure the next immediate user will not receive a slug of hot water if standing under the shower head when starting the shower.

**Important: DO NOT switch off the shower using the isolating switch before the phased shutdown process has completed. This may damage the unit.**

### Temperature Protection

During normal operation if the flow of water through the unit is restricted, power to the elements will be reduced to maintain the shower temperature. When the flow of water through the unit returns to normal, power to the elements will be automatically restored to the setting at the time of interruption.

### Safety Cut-out

The unit is fitted with an over-temperature safety device. In the event of abnormal operation which could cause unsafe temperatures within the unit, the device will disconnect the heating elements and remove power from the electronics making the shower unit inoperable.

**It will require a visit from a qualified engineer to identify the nature of the fault and replace the safety device.**

## IMPORTANT

The shower unit **MUST BE** switched off at the isolating switch when not in use. This is a safety procedure recommended for all electrical appliances.

## Instructions for installers and service engineers only

### Cleaning the Filter

It is recommended that the filter is periodically cleaned in order to maintain the performance of the shower. It is essential that this operation is carried out by a competent person.

**Switch off the electricity and water supply at the mains.**

The inlet filter is situated inside the water inlet fitting.

To gain access to the filter remove the cover and splashguard. Unscrew the inlet filter cap on the water inlet fitting.

Inspect the O-ring for damage when the filter is removed. Do not over tighten the filter cap on reassembly.

When cleaning the filter, **DO NOT** use a sharp object as it will cause damage. It is preferable to use an old toothbrush or similar.

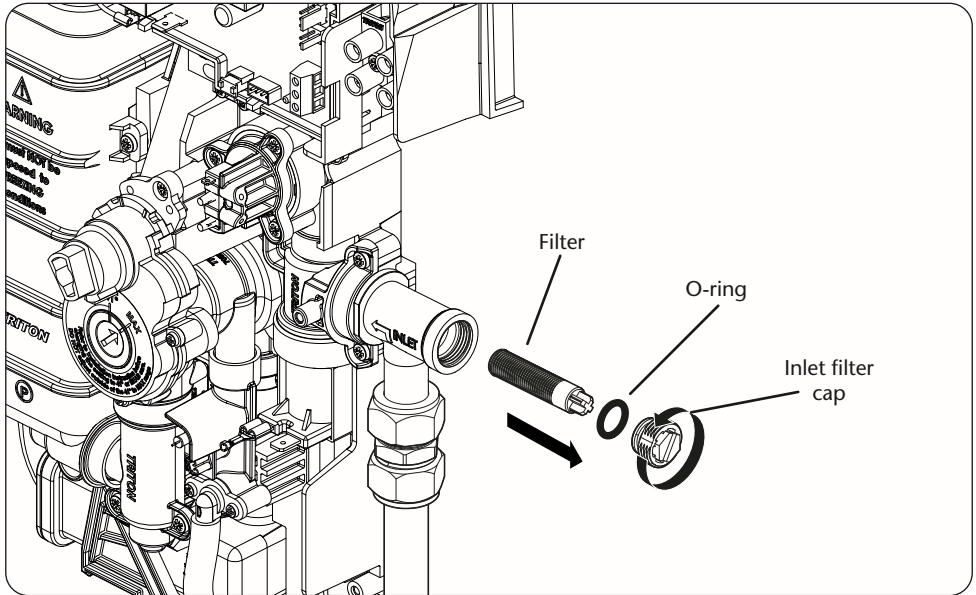

# MAINTENANCE - BEAB CARE

## **Important:**

These tests should only be performed by a qualified engineer.

### **Commissioning and In-Service Tests**

#### **D.1 Commissioning**

##### **D.1.1 Purpose**

Since the installed supply conditions are likely to be different from those applied in production it is appropriate, at commissioning, to carry out some simple checks and tests on each instantaneous water heater to provide a performance reference point for future in-service tests.

##### **D.1.2 Procedure**

**D.1.3** With the appliance turned off, check that:

- a) the water supply temperature is within the range 5 to 20°C;
- b) the terminal voltage at the appliance is within the range  $230 \pm 10\%$ .

**D.1.4** Turn on the appliance and if the maximum outlet water temperature is adjustable, adjust this in accordance with the manufacturer's instructions to the maximum permitted BEAB care temperature. Then carry out the following sequence:

- a) record the supply voltage at the terminals of the appliance;
- b) record the outlet water temperature and the flow rate resulting from the setting;
- c) reduce the water supply flow rate at the inlet of the appliance by at least 50% or to the lowest value at which the appliance continues to deliver an output of heated water, whichever is the greater pressure;
- d) record the outlet water temperature and the reduced flow rate;

The outlet water temperature should not exceed 43°C for a shower.

- e) record details of the equipment, thermometers etc, used for the measurements.

# MAINTENANCE - BEAB CARE

## D.2 In-service tests

### D.2.1 Principle

The purpose of in-service tests is to regularly monitor and record the performance of the instantaneous water heater. Deterioration in performance can indicate the need for service work on the appliance and/or the water supplies.

### D.2.2 Procedure

**D.2.3** Using the measuring equipment recorded in D.1.4 or equipment to the same specification and with the appliance turned off check that:

- a. the water supply temperature is within the range 5 to 20°C;
- b. the terminal voltage at the appliance is within the range  $230 \pm 10\%$ .

**D.2.4** If the set maximum outlet water temperature has changed significantly from the previous test results (e.g.  $> 1^\circ\text{C}$ ), record the change and before re-setting the maximum outlet water temperature check that:

- a) any outlet fittings are not blocked and are free of scale;
- b) any in-line or integral strainers are clean;
- c) any in-line or integral check valves or other backflow prevention devices are in good working order;
- d) any isolating valves are fully open.

**D.2.5** With an acceptable outlet water temperature, complete the following procedure:

- a) record the supply voltage at the terminals of the appliance.
- b) record the outlet water temperature and the flow rate resulting from the setting.
- c) reduce the water supply flow rate at the inlet of the appliance by at least 50% or to the lowest value at which the appliance continues to deliver an output of heated water, whichever is the greater pressure.
- d) record the outlet water temperature and the reduced flow rate.

**NOTE:** The outlet water temperature should not exceed 43°C for a shower and washbasin.

- e) record details of the equipment, thermometers etc. used for the measurements.

**D.2.6** If at step D.2.5 b) the outlet water temperature is greater than the values given in the note to D.2.5 d) then service work is indicated.

# MAINTENANCE - BEAB CARE

## **D.3 Frequency of in-service tests**

### **D.3.1 General**

In-service tests should be carried out with a frequency which identifies a need for service work before an unsafe water temperature can result. In the absence of any other instruction or guidance on the means of determining the appropriate frequency of in-service testing, the following procedure may be used:

**D.3.1.1** 6 to 8 weeks after commissioning, conduct the tests detailed in D.2.2 to D.2.6.

**D.3.1.2** 12 to 15 weeks after commissioning, conduct the tests given in D.2.2 to D.2.6.

**D.3.1.3** Depending on the results of D.3.1.1 and D.3.1.2 several possibilities exist:

- a) If no significant changes (e.g.  $\leq 1^{\circ}\text{C}$ ) in outlet water temperatures are recorded between commissioning and D.3.1.1, or between commissioning and D.3.1.2 the next in-service test can be deferred to 24 to 28 weeks after commissioning.
- b) If small changes (e.g.  $1$  to  $2^{\circ}\text{C}$ ) in outlet water temperatures are recorded in only one of these periods, necessitating adjustment of the outlet water temperature, then the next in-service test can be deferred to 24 to 28 weeks after commissioning.
- c) If small changes (e.g.  $1$  to  $2^{\circ}\text{C}$ ) in outlet water temperatures are recorded in both of these periods, necessitating adjustment of the outlet water temperature, then the next in-service test should be carried out at 18 to 21 weeks after commissioning.
- d) If significant changes (e.g.  $> 2^{\circ}\text{C}$ ) in outlet water temperatures are recorded in either of these periods, necessitating service work, then the next in-service test should be carried out at 18 to 21 weeks after commissioning or earlier.

**D.3.1.4** The general principle to be observed after the first 2 or 3 in-service tests is that the intervals of future tests should be set to those which previous tests have shown can be achieved with no more than a small change in outlet water temperature.

# FAULT FINDING

**Important:** Switch off the electricity at the mains supply and remove the circuit fuse before attempting any fault finding inside the unit.

<b>Problem</b>	<b>Cause</b>	<b>Action</b>
<b>1</b> Shower inoperable, no water flow.	<b>1.1</b> Interrupted power supply.	<b>1.1.1</b> Blown fuse or circuit breaker. Check supply Renew or reset fuse or circuit breaker. If it fails again, consult a qualified electrician.
	<b>1.2</b> Unit malfunction.	<b>1.2.1</b> Power cut? Check other appliances and if necessary, contact local Electricity Supply Co.
		<b>1.2.2</b> Have unit checked. Contact Customer Experience.
	<b>1.3</b> Thermal cut-out operated.	<b>1.3.1</b> The thermal cut-out safety device has operated. Have the unit checked by a suitably qualified service engineer or contact Customer Experience.
	<b>1.4</b> PCB - NTC has operated.	<b>1.4.1</b> The PCB has an NTC safety device which has operated. Have the unit checked by a suitably qualified service engineer or contact Customer Experience (lights and audio still in operation).
<b>2</b> Water too hot.	<b>2.1</b> Temperature control set incorrectly.	<b>2.1.1</b> Alter the temperature control.
	<b>2.2</b> Unit malfunction.	<b>2.2.1</b> Have the unit checked by a suitably qualified service engineer or contact Customer Experience.
<b>3</b> Water too cool or cold.	<b>3.1</b> Temperature control set incorrectly.	<b>3.1.1</b> Alter the temperature control.
	<b>3.2</b> Maximum temperature selector set incorrectly.	<b>3.2.1</b> Alter the maximum temperature selector.
	<b>3.3</b> Unit malfunction.	<b>3.3.1</b> Have the unit checked by a suitably qualified service engineer or contact Customer Experience.
<b>4</b> Water will not stop flowing from unit unless switched off at isolating switch.	<b>4.1</b> Control cable is not connected to PCB.	<b>4.1.1</b> Remove cover and connect cable.
<b>5</b> Pressure relief device has operated (water ejected from PRD tube).	<b>5.1</b> Blocked shower head.	<b>5.1.1</b> Clean sprayplate and then fit a new PRD.
	<b>5.2</b> Twisted/blocked flexible shower hose.	<b>5.2.1</b> Check for free passage through hose. Replace hose if necessary and then fit new PRD.
	<b>5.3</b> Shower head not removed while commissioning.	<b>5.3.1</b> Fit new PRD. Commission unit with shower head removed.

# FAULT FINDING

<b>Problem</b>	<b>Cause</b>	<b>Action</b>
<b>6</b> Low flow LED permanently ON when start/stop is pressed. Shower will not start.	<b>6.1</b> Low flow condition.	<b>6.1.1</b> Insufficient water flow available. 1. Check shower head is not blocked. 2. Check shower hose is not restricted. 3. Check filter is not blocked. 4. Check water supply to shower is adequate.
<b>7</b> Low flow LED comes ON when shower is running. Shower switches off.	<b>7.1</b> Low flow condition has caused temperature sensor in the shower to operate.	<b>7.1.1</b> Shower will not start until water in the unit has cooled and LED goes off. If problem persists. 1. Check shower head is not blocked. 2. Check shower hose is not restricted. 3. Check filter is not blocked. 4. Check water supply to shower is adequate.
<b>8</b> Low flow LED FLASHES CONTINUOUSLY when start/stop is pressed. Shower will not start.	<b>8.1</b> Flow sensor has failed.	<b>8.1.1</b> Replace flow sensor assembly.
	<b>8.2</b> Pressure switch has failed.	<b>8.2.1</b> Replace pressure switch assembly.
<b>9</b> Low flow and shutdown LEDs FLASH ALTERNATELY when power turned on to unit. Shower will not start.	<b>9.1</b> Start/Stop PCB failed.	<b>9.1.1</b> Replace cover assembly.
<b>10</b> Low flow, shutdown and start stop LEDs FLASHING SIMULTANEOUSLY. No buzzer sound.	<b>10.1</b> Outlet thermistor failed.	<b>10.1.1</b> Replace thermistor.
<b>11</b> Low flow, shutdown and start/stop LEDs FLASH SIMULTANEOUSLY. Continuous buzzer beep.	<b>11.1</b> NTC failure.	<b>11.1.1</b> Replace power PCB.

Note: Identify cause of operation before fitting new PRD unit. When fitting a new PRD, follow the commissioning procedure.

It is advised all electrical maintenance/repairs to the shower should be carried out by a suitably qualified person.

In the unlikely event of unit failure other than detailed in the fault finding page, please contact Customer Experience for advice.

## **SUBJECT: Alternative Format User Instructions**

The User Instructions are available in the following alternative formats;

### **Descriptive Word Document Extra Large Print**

Alternative format User Instructions are available for this shower and the Remote start/stop button accessory.

Should you require a copy of the alternative User Instructions please contact

Triton Customer  
Experience  
on **024 7637 2222**

## SPARES

To purchase a genuine Triton spare part for your product, please visit

**[www.tritonshowers.co.uk/spares](http://www.tritonshowers.co.uk/spares)**

for product codes and prices.

Alternatively please call our Customer Experience team on

**024 7637 2222** to order direct.

Please have your model name available.

For spare parts or service enquiries in **Ireland** please visit

**[www.tritonshowers.ie/spares](http://www.tritonshowers.ie/spares)**

for product codes and prices.

Alternatively please call our Customer Services team on

**01 628 6711** to order direct.

Please have your model name available.





## UK SERVICE POLICY

**In the event of a product fault or complaint occurring, the following procedure should be followed:**

### **DO NOT REMOVE THE PRODUCT**

1. Telephone Customer Experience on **024 7637 2222** having available your details including post code, the model number and power rating of the product, together with the date of purchase and, where applicable, details of the particular fault.
2. If required, the Customer Experience Advisor will arrange for a qualified engineer to call.
3. All products attended to by a Triton service engineer must be installed in full accordance with the Triton installation guide applicable to the product; this can be downloaded free at [www.tritonshowers.co.uk/guides](http://www.tritonshowers.co.uk/guides).
4. Our engineer will require local parking and if a permit is required, this must be available to the engineer on arrival at the call.
5. If loft access is required for isolation or to complete a repair, the loft must have a fixed access ladder and be boarded, with appropriate lighting from the access point to and around the repair area.
6. It is essential that you or an appointed representative, who must be over 18 years of age, is present for the duration of the service engineer's visit. If the product is in guarantee you must produce proof of purchase.
7. Where a call under the terms of guarantee has been booked and the failure is not product related (i.e. scaling and furring, incorrect water pressure, pressure relief device operation or electrical/plumbing installation fault) a charge will be made. A charge will also be issued if nobody is at the property when the service engineer calls or adequate parking/permit is not available.
8. If the product is no longer covered by the guarantee an up-front fixed fee will be charged before the site visit.
9. Your receipt must be retained as proof of purchase. Should proof of purchase not be available on an 'in-guarantee' call, or should the service engineer find that the product is no longer under guarantee, the engineer will charge the same fixed price and will request payment prior to departing. If payment is not made on the day an administration charge will be added to the fixed charge.
10. If a debt is outstanding from a previous visit, or from any other Triton purchase, Triton reserves the right to withhold service until the debt has been settled.
11. Triton takes the health, safety and wellbeing of its employees very seriously and expects customers to treat all staff members with respect. Should any employee feel threatened or receive abuse, either verbally or physically, Triton reserves the right to withhold service.

### **Replacement Parts Policy**

In line with AMDEA guidelines, Triton retains functional spares for as long as there is a market for them and in most cases, well beyond. Due to the vast array of product types, the life cycle of products can vary and therefore so can the length of time parts can be supplied. Spare parts can be ordered via our online spare parts store or by telephoning Triton Customer Experience team on **024 7637 2222**. Payment should be made by credit / debit card (excluding American Express or Diners Card). Payment can also be made by pre-payment of a pro-forma invoice, by cheque or postal order.

**Telephone orders are based on information given during the call. Before contacting Triton, please verify your requirements using the Triton website or your professional installer. Triton cannot accept liability for incorrect part identification.**

Triton Showers  
Triton Road  
Nuneaton  
Warwickshire, CV11 4NR

Triton is a division of Norcros Group (Holdings) Limited

Triton reserve the right to change product specification without prior notice. E&OE. © TRITON SHOWERS 2024

## TRITON UK STANDARD GUARANTEE

This guarantee applies only to products installed within the United Kingdom and does not apply to products used commercially. This guarantee does not affect your statutory rights.

With the exception of accessories, Triton guarantee the product against all manufacturing defects for a period of **2 years** (for domestic use only) from the date of purchase, provided that it has been installed by a competent person in full accordance with the fitting instructions.

All accessories such as shower heads, hoses and riser rails carry a **1 year** parts only guarantee against manufacturing defects.

Any part found to be defective during this guarantee period we undertake to repair or replace at our option without charge, so long as it has been properly maintained and operated in accordance with the operating instructions and has not been subject to misuse or damage. This product must not be taken apart, modified or repaired except by a person authorised by Triton.

### **What is not covered:**

1. Breakdown due to:
  - a) use other than domestic use by the property occupants;
  - b) wilful act or neglect;
  - c) any malfunction resulting from the incorrect use or quality of electricity, gas or water or incorrect setting of controls;
  - d) failure to install in accordance with this installation guide.
2. Claims for missing parts once the product has been installed.
3. Repair costs for damage caused by foreign objects or substances.
4. Total loss of the product due to non-availability of parts.
5. Compensation for loss of use of the product or consequential loss of any kind.
6. Call out charges due to an abortive visit or where no fault has been found with the appliance.
7. The cost of repair or replacement of isolating switches, electrical cable, fuses and/or circuit breakers or any other accessories installed at the same time. Replacement of a Pressure Relief Device that only activates when the shower outlet is blocked is also excluded.
8. The cost of routine maintenance, adjustments, overhaul modifications or loss or damage arising therefrom, including the cost of repairing damage, breakdown, malfunction caused by corrosion, furring, frost or exposure to freezing conditions.
9. Callout charges where the water supply cannot be isolated, this includes consequential losses arising from unserviceable supply valves, or inaccessible product or valves located in a loft space without suitable access.

### **For the latest Terms & Conditions please see:**

[www.tritonshowers.co.uk/terms](http://www.tritonshowers.co.uk/terms)

PLEASE NOTE PRODUCT REGISTRATION IS ONLY AVAILABLE TO UNITS PURCHASED & INSTALLED IN THE UK

Customer Experience: 024 7637 2222  
Trade Installer Hotline: 024 7637 8344  
[www.tritonshowers.co.uk](http://www.tritonshowers.co.uk)  
E-mail: [CXsupport@tritonshowers.co.uk](mailto:CXsupport@tritonshowers.co.uk)  
E-mail: [technical@tritonshowers.co.uk](mailto:technical@tritonshowers.co.uk)